



URBACO

AUTOMATIC BOLLARDS

**INSTALLATION MANUAL - URBACO
U200 & U201 CONTROL BOARDS
Article code: 002ZU200
Version V8**

**THIS MANUAL IS ONLY FOR PROFESSIONAL
OR QUALIFIED PERSONNEL**



**ELECTRIC SHOCK
HAZARD**

CONTENT

1. PRESENTATION	3
1.1. General features.....	3
1.2. Casing layout.....	4
1.3. Description of control boards U200 e U201	5
1.3.1. The U200 control board	5
1.3.2. The U201add-on-card for 2nd access.....	5
2. TECHNICAL SPECIFICATIONS	6
3. INSTALLATION AND CONNECTIONS	7
3.1. How to fix the casing	7
3.2. How to connects the U200 control board and U201add-on-card for 2nd access.....	7
3.2.1. Connecting the bollards and its accessories	7
3.2.2. Connecting the compressor	8
3.2.3. Connecting main supply	8
3.3. How to connect the logic system	9
3.3.1. Controlled entrance and automatic exit.....	9
a) Installation of loops.....	9
b) Connecting the detector contacts	9
c) Connecting the loops.....	9
3.3.2. Controlled entrance and exit.....	10
a) Installation of loops.....	10
b) Connecting the detector contacts	10
c) Connecting the loops.....	10
3.3.3. Automatic exit.....	11
a) Installation of loops.....	11
b) Connecting the detector contacts	11
c) Connecting the loops.....	11
3.3.4. None.....	12
3.4. How to connect an external timer or a forced retracting function.....	12
4. PARAMETERS SETTING AND PROGRAMMING	
4.1 Parameters setting	13
4.2 Programming of a TOP or TAM transmitter with receiver AF43S	13
5. OPERATION	14
5.1. Control board power on	14
5.2. Power outage	14
5.3. Operation on a retracting command (normal passage)	14
5.4. Operation in manual mode (rising and retracting by controller)	14
5.5. Operation of emergency stop	14
5.6. Operation on an automatic exit	14
5.7. Safety during rising.....	14
5.8. Locking in the upward position.....	15
5.9. Operation of compressor surveillance.....	15
5.10. Compressor management	15
5.11. Loss of upper limit switch while bollard locked upward	15
5.12. LED status indicators.....	15
5.13. Negative security/ Failsafe.....	15
5.14. Maximum number of bollards.....	15
5.15. Traffic lights indicating bollard status	15
5.16. Access default	15
6. MAINTENANCE	16
7. TROUBLE SHOOTING	17

1. PRESENTATION

1.1. General features:

This manual describes the setup and operation of Urbaco U200, version V8, control board intended for the management of URBACO's pneumatic-driven retractable bollards.

As a standard the casing consists of a U200 control board which runs one access and of a transformer. Using the optional U201 add-on-card connected to the U200 it is possible to run a 2nd access. The detectors/sensors for the safety loops may be built in the casing, depending on the operating logic mode chosen.

The U200 board has a socket designed for CAME plug-in boards. Programming the board depending on operating mode selected is done with switches and with a potentiometer. Finally, 4 x LEDs give indications on the status of some functions.

Directions for the good use of an access site controlled by automatic retractable bollard(s)

SAFETY RULES FOR THE GOOD USE OF AN ACCESS SITE CONTROLLED BY AUTOMATIC RETRACTABLE BOLLARD(S)

So as to ensure the good functioning of the access and for safety reasons URBACO recommends:

- **To set up vertical signposts warning of an obstacle («retractable bollard») ahead.**
- **To equip the automatic bollards with flashing lights (red and yellow flashing lamps)**

For the access control systems, URBACO recommends that a vehicle **is obliged to stop before the bollard and waits for its complete retraction underground** (and for the light to turn from red to flashing amber if the access site has position lights) **prior to driving on.**

In case of bollards automatically rising once a vehicle has passed, the following vehicles **must not try and drive through the access site one after the other without each stopping before the bollard, making sure it is retracted and respect signal given by position light (if such a device has been installed).**

INFORMATION AND TRAINING OF USERS

The person(s) in charge of the access site is (are) bound to inform users on how to operate and utilise the access. URBACO will not be held responsible for any damage due to mishandling or to disrespecting safety rules.

1.2. Casing layout:

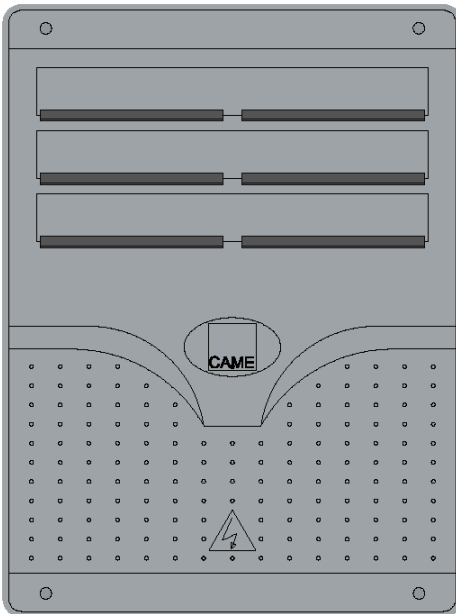

Closed casing

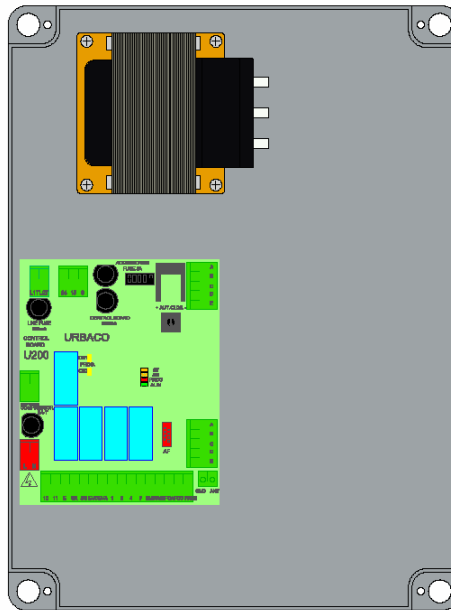

Casing with U200 board

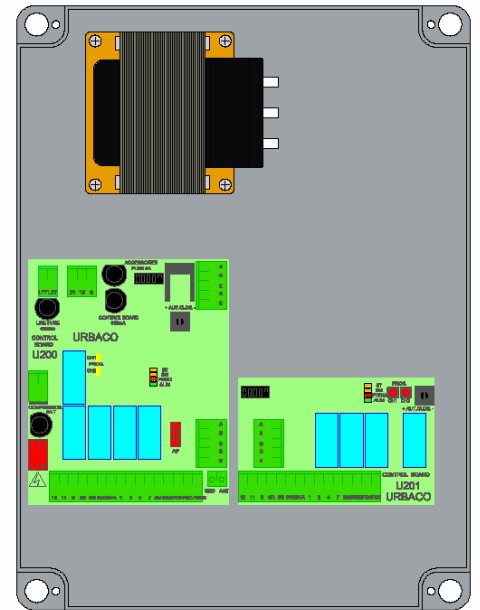

Casing with U200 board and U201 add-on-card

1.3. Description of U200 control board and U201 add-on-card:

1.3.1. The U200 control board:

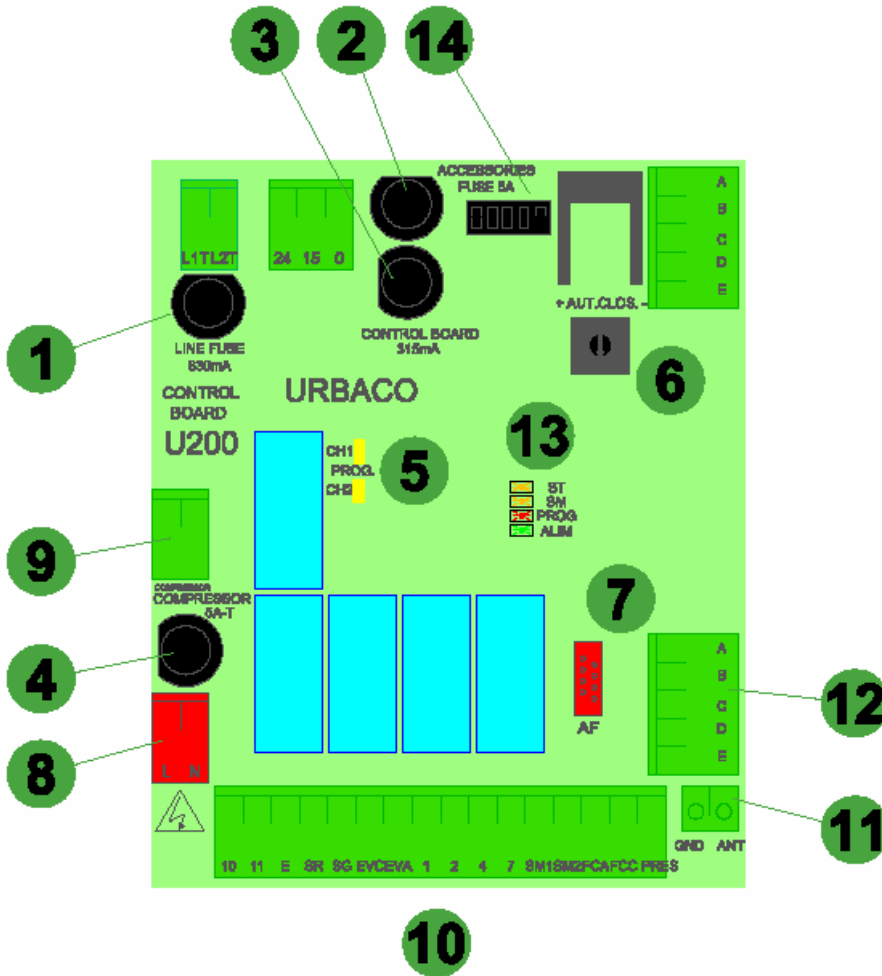

- 1 Fuse: 630 mA line
- 2 Fuse: 5 A Accessories
- 3 Fuse: 315 mA control board
- 4 Fuse: 5 AT compressor
- 5 Programming switches for CH1 and CH2 radio transmitters
- 6 Time control setting before automatic rise
- 7 Sockets for Came plug-ins: AF43S, AF43SM, AF43SR, AF30, AF150
- 8 230 V main supply terminal
- 9 230 V compressor supply terminal
- 10 Terminal strip
- 11 Radio antenna terminal
- 12 U201 connection terminal
- 13 LED status indicators
- 14 Parameters setting switches

1.3.2. The add-on-card U201 for 2nd access:

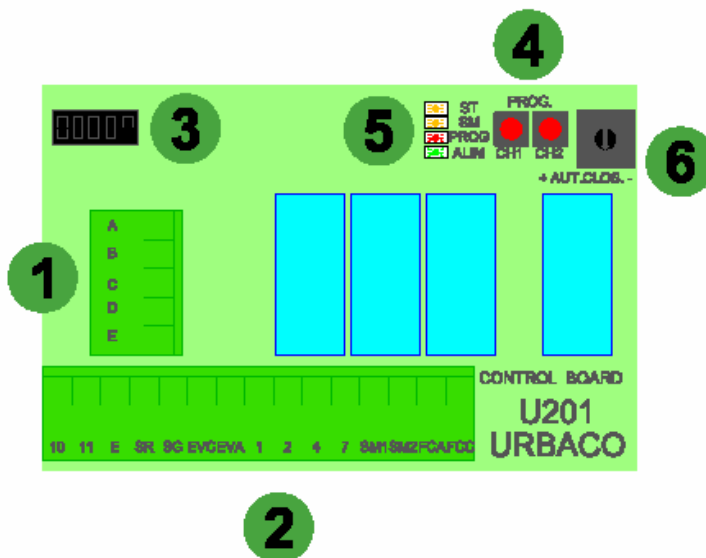

- 1 U200 connection terminal
- 2 Terminal strip
- 3 Parameters setting switches for 2nd access
- 4 Programming buttons for CH1 e CH2 transmitters
- 5 LED status indicators
- 6 Time lapse relay before automatic rise

2. Technical Specifications

General specifications:

Casing	:	ABS plastic
IP	:	IP 54
IK	:	IK 8
Cable input	:	4 inputs for PE Ø10 (not supplied)
Weight	:	3,5 kg // 7.7 lbs
Dimensions (H x L x D)	:	320 x 240 x 150 mm // 12.6 x 9.44 x 5.9 in.

Electrical specifications:

Supply tension	:	230 V, 1-phase
Consumption:	:	< 1 A (U200 only)
Frequency:	:	50 Hz
Electrical insulation:	:	Class II

Bollard specifications:

- From 1 to 4 automatic retractable bollards for the pneumatic version
- Management of upper and lower limit switches by URBACO
- Management of induction loops via 1- or 2-way detectors (depending on operating logic mode)
- Compressor surveillance
- Management of external controllers by dry contact
- Operation of n°5 Urbaco G6 solenoid valves (8W) and up to 8 Luxor solenoid valves (8W).

A maximum power of 20W is available on output for accessories.

The U200 and U201 control boards do not have any diagnose for operation faults except for compressor surveillance.

Limit switches are managed without possibility of error detection or diagnosis.

3. INSTALLATION AND CONNECTIONS

3.1. How to fix the casing:

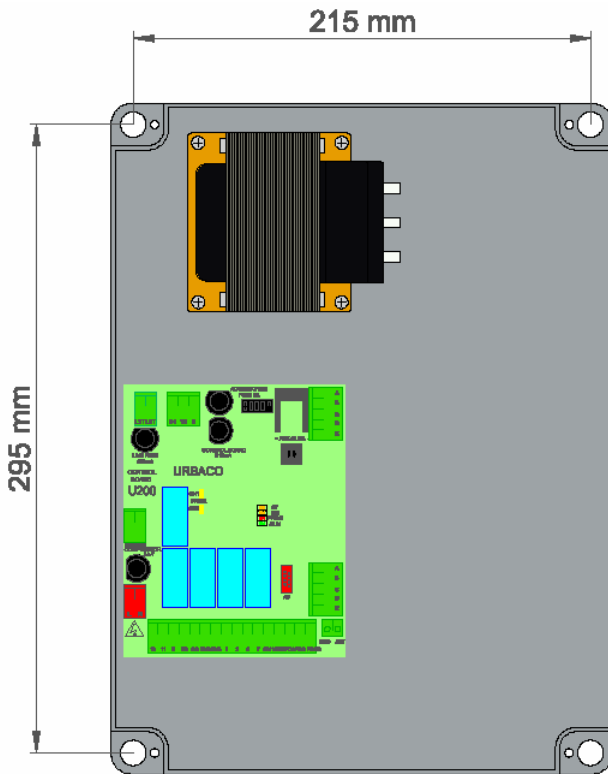

This case is suitable for wall-mount inside any premises or built in a cabinet or CITY-type controller

215 mm = 8.46 in

295 mm = 11.61 in

3.2. How to connect the U200 control board and U201 add-on-card for 2nd access:

3.2.1. How to connect the bollard and its accessories:

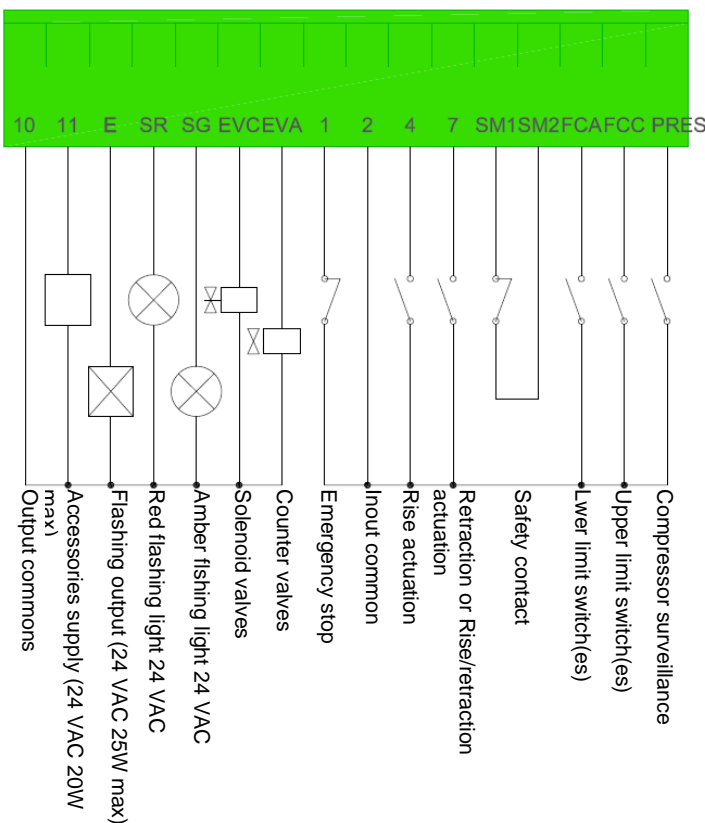

When several bollards are present on 1 access, apply parallel connections for solenoid valves and series connections for limit switches. Compressor surveillance is not available on U201 add-on-cards.

3.2.2. Connecting the compressor:

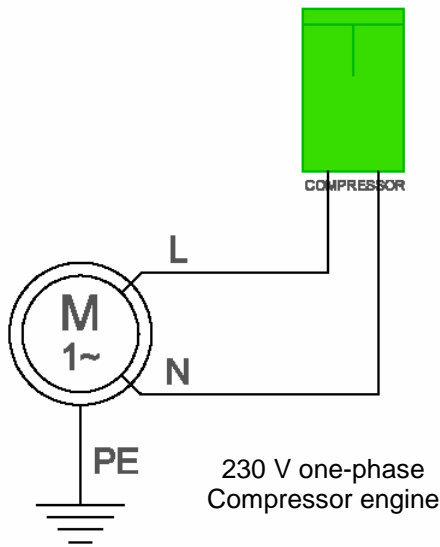

This supply terminal permits to disconnect the compressor in case of extensive use, when the compressor surveillance contact is connected.

3.2.3. Connecting the main supply:

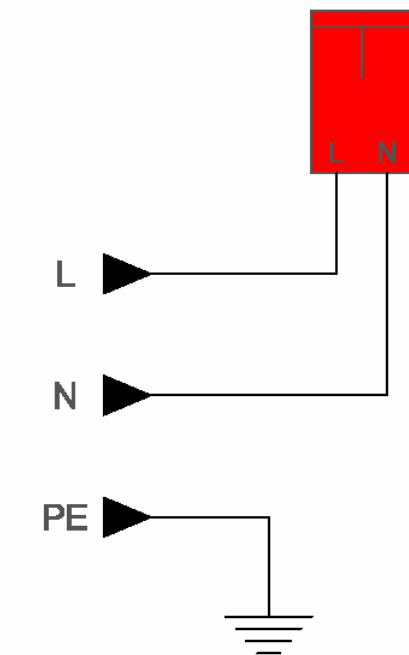

230 V one-phase
16 A main supply

It's obligatory to use differential protection for 30mA 16A power supply. Earth/ground wire of power supply must be connected to all components with earth/ground connectors.

The controller metal body must be earthed/grounded when the U200 is not protected with a cover. (Class I)

3.3. How to connect the logic system:

3.3.1. Controlled entrance and automatic exit:

a) Installation of loops:

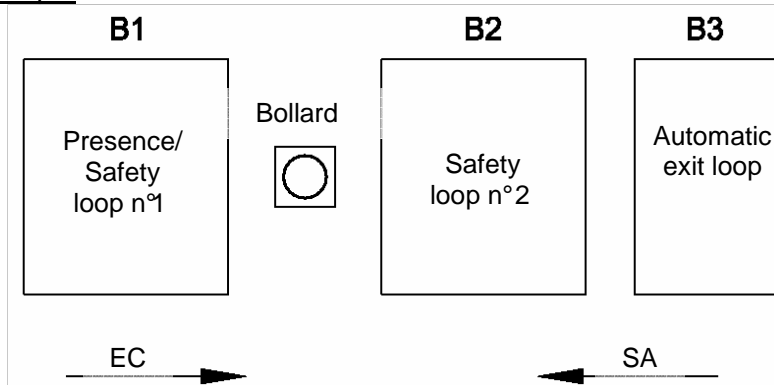

b) Connecting the detector contacts (sensors):

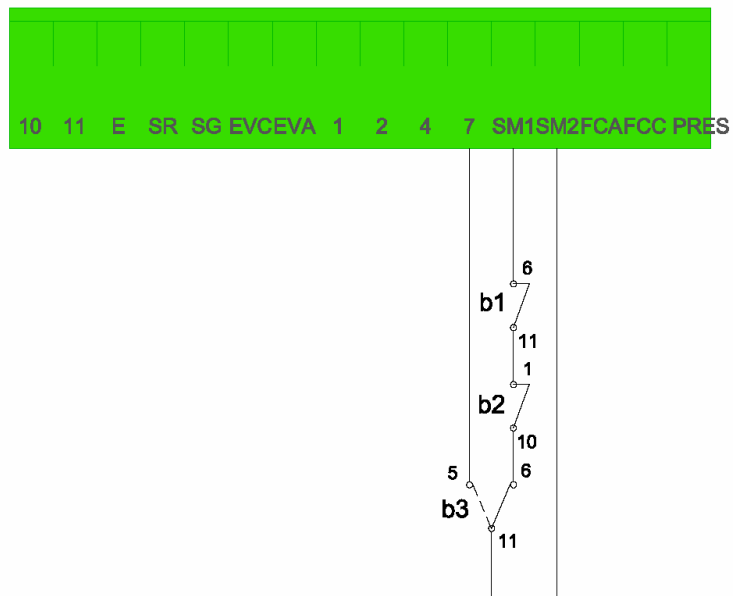

c) Connecting the loops:

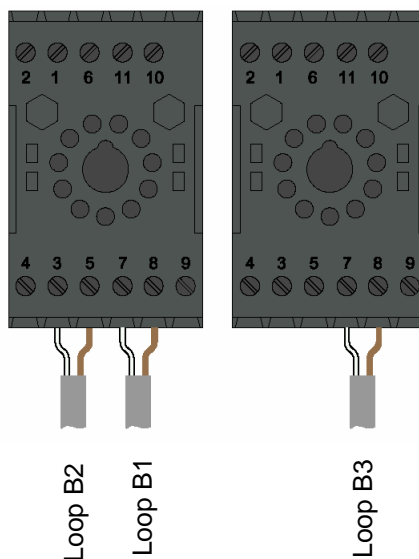

3.3.2. Controlled entrance and exit:

a) Installation of loops:

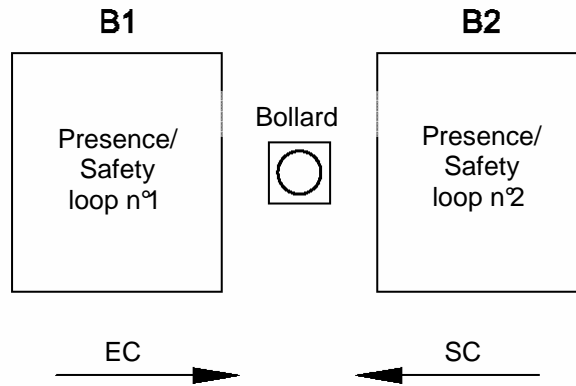

b) Connecting the detector contacts:

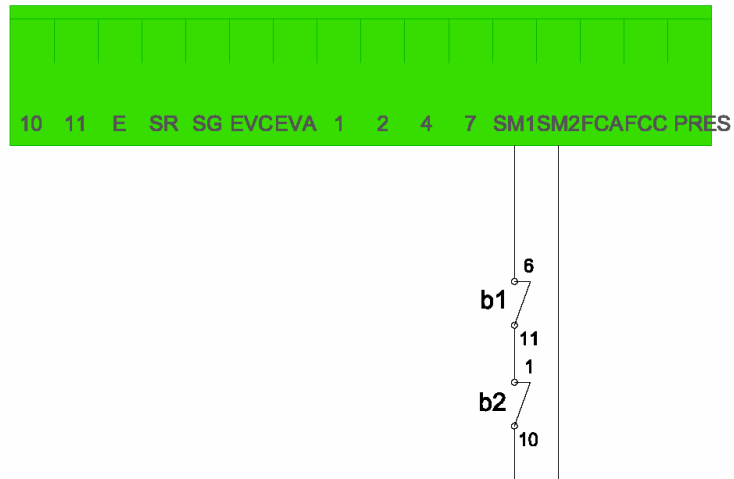

c) Connecting the loops:

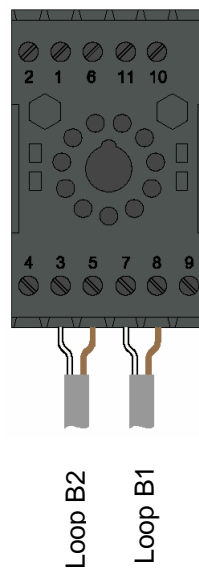

3.3.3. Automatic exit:

a) Installation of loops:

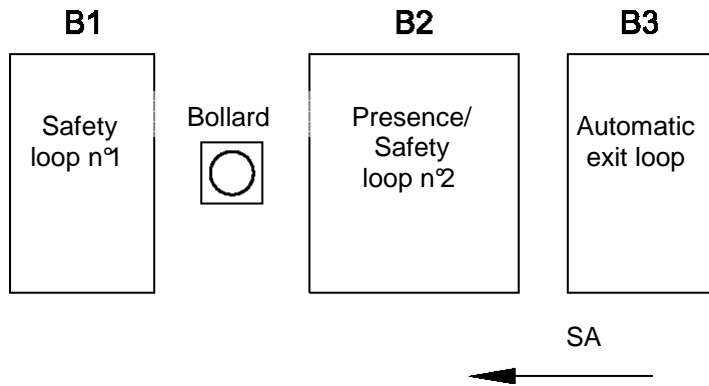

b) Connecting the detector contacts:

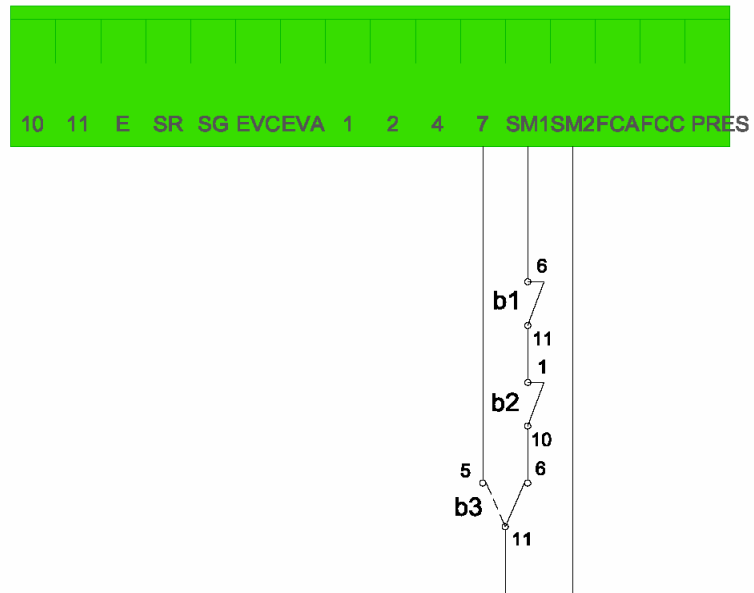

c) Connecting the loops:

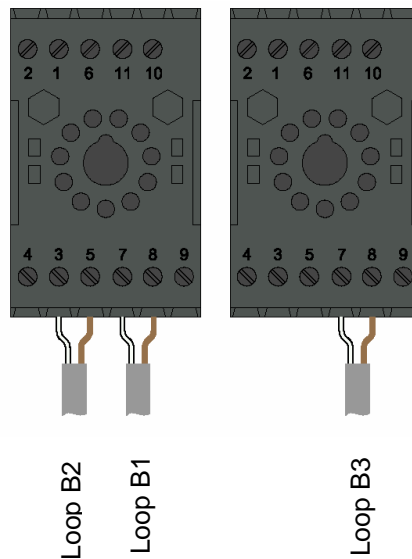

3.3.4. None:



3.4. How to connect an external timer or a forced retracting function:

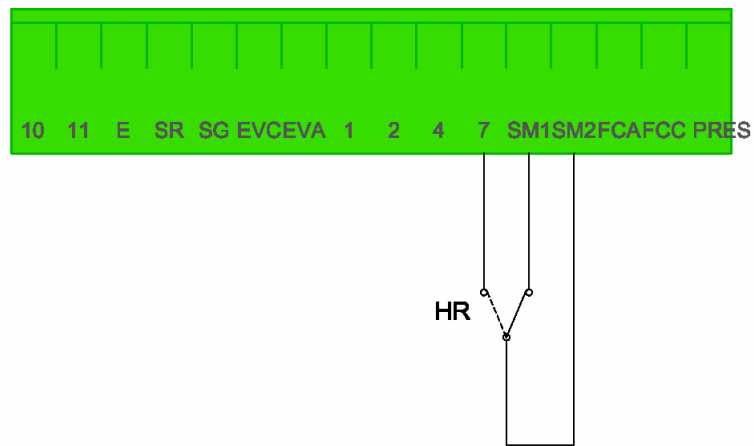

4. PARAMETERS SETTING AND PROGRAMMING

4.1. Parameters setting:

Five switches permit to set the board in such a way:

	ON	OFF
DIP n°1	Automatic closure enabled	Automatic closure disabled
DIP n°2	Only opening enabled	Only opening disabled
DIP n°3	Preflashing 3" enabled	Preflashing 3" disabled
DIP n°4	Programming (see table below)	
DIP n°5		

Switch		Button		Led" After 5"	Options
N°4	N°5	CH1	CH2		
ON		ON		ON	Bistable solenoid valve active
ON		ON		OFF	Monostable solenoid valve active
ON			ON	ON	Acoustic device and red traffic light flashing activated
ON			ON	OFF	Acoustic device deactivated
	ON	ON		ON	Green traffic light activated
	ON	ON		OFF	Orange traffic light activated
	ON		ON	ON	"Presence" function activated (the bollards retracts only in case the loop detects a metal mass)
	ON		ON	OFF	"Presence" deactivated

Turn the dip 4 and 5 into ON, then press CH1 or CH2. The led begins to flash.
 If after 5" the Led remains ON it means that the option has been activated.
 If the Led remains OFF it means that the option has been deactivated.

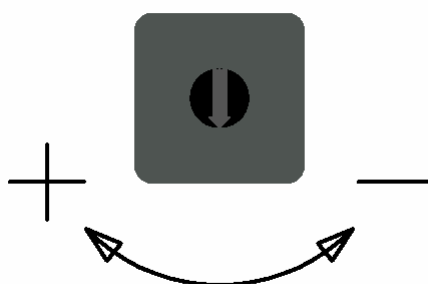

4.2. Transmitter TOP or TAM programming with receiver AF43S :

With power supply on, keep CH1 button of U200 card pressed (the PROG light flashes), and input the code by pressing the transmitter key (the light PROG stays ON to indicate that the memorisation has succeeded).

5. OPERATION

5.1. Control board power on: (when all connections are made)

The bollard rises if the board is programmed on Auto and if safety loops are cleared. In case of manual configuration (step by step) the bollard remains retracted until the rising command is given.

5.2. Power outage:

The bollard retracts underground and rises back when power is back if the board is programmed on automatic and if safety loops are cleared.

The bollard is in the retracted position in the manual configuration (step by step)

If the bollard has the negative safety option it does not retract in case of power outage.

5.3. Operation on a retracting command (normal passage):

SW1 = ON and adjustment of warning time frame before bollard rises.

- Descent actuation with presence (SW5=ON)

The descent actuation will only be taken into account if a vehicle is present on presence / safety loop N°1 (SM1/SM2 open)

In this case, the bollard rises once the safety loops have been cleared (SM1/SM2 closed) and after the warning time (if SW3 = ON)

- Descent actuation without presence (see table 4.1)

The bollard retracts immediately each time it is actuated down and rises once the safety loops have been cleared (SM1/SM2 closed) and after the warning time (if SW3 = ON).

5.4. Manual mode functioning (rising and retracting by command):

SW1 = OFF e SW2 = ON

Input N°7 is where the bollard up and down receives impulses to do so.

An impulse on 7 immediately triggers the bollard down (see table 4.1), a second impulse will trigger the bollard back up if no vehicle is present on the safety loops (SM1/SM2 closed) and after the warning time (if SW3 = ON).

SW1 = OFF e SW2 = OFF

Input N°7 triggers the bollard down and input N°4 triggers the bollard up.

An impulse on 7 immediately triggers the bollard down (see table 4.1), an impulse on N°4 will trigger the bollard upward if no vehicle is present on the safety loops (SM1/SM2 closed) and after the warning time (if SW3 = ON).

5.5. Operation of emergency stop mode:

The emergency stop button (NF) between 1 and 2 will trigger the bollard down. As long as it is pushed in, the bollard cannot rise. If the button is released, the bollard remains retracted (down). The bollard needs to be actuated up by remote control to be able to rise again. This operation mode is in compliance with the 'machine directive'.

If it were necessary that the bollard rises by releasing the emergency button, do cable connections as indicated on page 12.

5.6. Operation on an automatic exit:

Wiring the automatic exit detector to the system is another way to trigger the bollard down. Bollard will rise again like in a normal drive-through situation.

5.7. Safety during rising:

- It is necessary to connect bollards' upper and lower limit switches.

- Securities SM1 e SM2 are active as long as the upper limit switch is not activated.

5.8. Locking in the upward position:

When the upper limit switch is activated, the access is blocked.

5.9. Operation of compressor surveillance:

A dry contact on pressure gauge is used to control time during which compressor is in service. When motor is on, the contact is closed. When the motor stops, the contact opens. As soon as the solenoid valve is actuated, time lapse relay starts. If the compressor works for 5 minutes, the operation is stopped due to a lack of power on the COMP exit. In this case the bollards retract and it will be necessary a technical intervention

5.10. Compressor management:

The compressor works on its own. The 230V mains supply is continuous in normal operation. The pressure gauge built in runs the 'on' and 'off' status of the compressor to maintain air pressure in circuit.

5.11. Loss of Upper Limit Switch while bollard locked upward:

Does not affect the system

5.12. LED status indicators:

ST = ON ⇒ STOP during rise – OFF ⇒ Normal

SM = ON ⇒ SAFETY activated – OFF ⇒ Normal

PROG = Programming of transmitter and pre-flashing during the automatic retraction. See also par. 4.1

ALIM = ON ⇒ board powered on

5.13. Negative security / Failsafe:

Negative security (failsafe) is meant to maintain the bollard upward in case of a power outage. This function is not directly managed by the U200 board but this can be done by supplying a counter-valve between 10 and EVA; the counter-valve is placed on the normal solenoid valve exhaust

5.14. Maximum number of bollards:

5 x bollards maximum, of whatever size and diameter.

NB: the type of compressor used also determinates the number of bollards (see documentation on compressors).

5.15. Traffic lights indicating bollard status:

Read light= steady when the bollard is upward

Flashing when the bollard is in motion

Yellow light= Flashing when the bollard is down (retracted)

N.B.: the lower limit switch is necessary for the traffic light management

5.16. Access default:

No default management, except for compressor surveillance.

6. MAINTENANCE

No special maintenance is prescribed for the U200 ; technical checkups are however advisable to control the general state of material (absence of dust, humidity...), operativeness of safety equipments (vehicle detection), operativeness of control devices (beeper, contactless cards...) and to tighten loose connections inside the case.

These maintenance interventions are to be envisaged by operators depending where the case is located and how often it is used (intensive or non-intensive use).

7. TROUBLE SHOOTING

Nature of problem	Solutions
The power LED is off	<ul style="list-style-type: none"> - Check power supply with a controller - Check connections - Check fuses
Transmitters non active	<ul style="list-style-type: none"> - Transmitters are not programmed or badly programmed - No vehicle on loop (see table 4.1) - Transmitters are out of order - Radio Board - Antenna
External control device non active	<ul style="list-style-type: none"> - Check power and connections - Check vehicle presence (see table 4.1) - Check programming or/and configuration
The bollard does not rise	<ul style="list-style-type: none"> - SM1/SM2 is open - Time lapse relay for automatic rise is not over - The board is setted on manual operation mode(SW1)
The bollard does not rise even when power is on	<ul style="list-style-type: none"> - Try impulse on n°7 - SM1/SM2 is open
Flashing lights are not working correctly	<ul style="list-style-type: none"> - Check limit switches (they may have been inverted) - Check 24V A.C. power supply on exits SR
Compressor does not start	<ul style="list-style-type: none"> - Check fuses - Check connections - Check the compressor

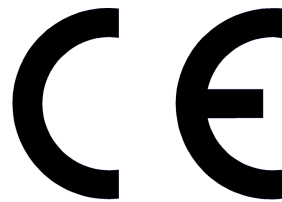

Type: 002ZU200V8

Edition 2008

URBACO S.A. – Z.A. du Couquiou 84320 ENTRAIGUES – France

Tel.: +33 490 480 800 - Fax: +33 490 480 088

Website: www.urbaco.com

E-mail: export@urbaco.fr